

HRG14**S1P

SPECIFICATIONS

Compressor

- High-efficiency scroll compressor
- R410A refrigerant
- Grommet mounted compressor for quiet operation
- Heavy-duty compressor sound blanket for quiet operation
- Internally protected against high temperature motor overload conditions

Cabinet

- Full metal louvered construction to protect the coil
- Individual metal louvered panels remove easily for coil cleaning and service
- Corner-mounted controls for easy service
- Baked polyester paint finished over galvanized steel for maximum durability
- External gauge ports for easy service

Design

- Designed to perform in temperatures up to 125°F
- Designed to perform in temperatures down to 0°F

Coils

- Total corrosion protection technology designed coil
- Enhanced tube-and-fin coil design
- Lanced fins for maximum heat transfer
- Factory tested for leakproof construction
- Raised coil prevents debris from impeding airflow

Components

- 45-degree offset gauge ports for easy service
- Factory installed high and low pressure switches
- Thread-on pressure switches for simple, quick service
- Factory installed filter dryer
- Fan shroud for smoother airflow and sound level reduction
- Charged for 15 feet of line set
- Discharge muffler for quiet operation
- Units are capable of reducing noise during defrost



SPLIT SYSTEM HEAT PUMP

*14 SEER High Efficiency
Up to 16 SEER & 9.0 HSPF*



For the latest AHRI system matches,
please visit AHRIdirectory.org

MODEL NUMBER GUIDE

H	R	G	14	24	S	1	P
Heat Pump	Residential Split	'Green' Gas R-410A	SEER 14	Capacity BTUH x 1000	S = Scroll Compressor	Power 1 = 208/230-1-60	Series/ Revision

PHYSICAL AND ELECTRICAL DATA

Model	Voltage/Hz/Phase	Voltage Range	Min. Circuit Amp.	Max. Over Current Device (amps)	Compressor		Outdoor Fan Motor			Shipping Weight (lbs.)
					Rated Load (amps)	Locked Rotor (amps)	Full Load (amps)	Rated HP	Nom. RPM	
HRG1418S1P	208-230/60/1	197-253	12.3	20	9.0	48	1.1	1/6	825	182
HRG1424S1P	208-230/60/1	197-253	17.9	30	13.4	58	1.1	1/6	825	184
HRG1430S1P	208-230/60/1	197-253	17.1	25	12.8	64	1.1	1/6	825	183
HRG1436S1P	208-230/60/1	197-253	18.7	30	14.1	77	1.1	1/6	825	199
HRG1442S1P	208-230/60/1	197-253	25.8	45	19.2	123.9	1.8	1/4	825	249
HRG1448S1P	208-230/60/1	197-253	26.2	45	19.6	130	1.8	1/4	825	252
HRG1460S1P	208-230/60/1	197-253	29.6	50	22.2	127.9	1.8	1/4	825	270

Note:
Weights listed are unit weights with packaging
+ Factory charged for 15 feet of line set. Adjust per installation instructions.

UNIT DIMENSIONS AND SOUND RATINGS

Model	Dimensions (inch)			Sound Rating (dBA)
	A - Width	B - Depth	C - Height	
HRG1418S1P	28-1/4	28-1/4	43-1/4	76
HRG1424S1P	28-1/4	28-1/4	43-1/4	76
HRG1430S1P	28-1/4	28-1/4	43-1/4	76
HRG1436S1P	28-1/4	28-1/4	37-1/4	76
HRG1442S1P	32-1/4	32-1/4	37-1/4	79
HRG1448S1P	32-1/4	32-1/4	37-1/4	80
HRG1460S1P	32-1/4	32-1/4	43-1/4	80

Note:
Dimensions listed are unit sizes w/o packaging

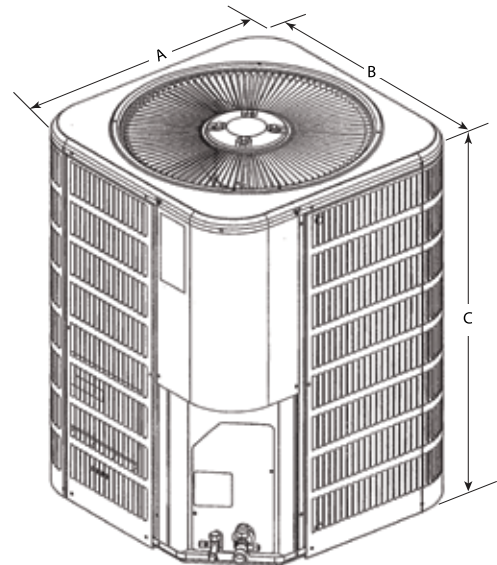

REFRIGERATION DATA

Model	Refrig. Charge (oz.) *	TXV	Outdoor Unit Connection		Refrigerant Line Size	
			Suction	Liquid	Suction	Liquid
HRG1418S1P	112	H4TXV01	3/4	3/8	3/4	3/8
HRG1424S1P	115	H4TXV01	3/4	3/8	3/4	3/8
HRG1430S1P	115	H4TXV01	3/4	3/8	3/4	3/8
HRG1436S1P	161	H4TXV02	7/8	3/8	7/8	3/8
HRG1442S1P	171	H4TXV02	7/8	3/8	7/8	3/8
HRG1448S1P	171	H4TXV02	7/8	3/8	7/8	3/8
HRG1460S1P	193	H4TXV03	7/8	3/8	1 1/8	3/8

Note:
* Factory charged for 15 feet of line set; adjust per installation instructions.

PERFORMANCE WITH COILS, AIR HANDLERS AND FURNACES

Outdoor Model	Indoor Model	Cooling				Heating		
	Evap. Coil Air Handlers ¹	SEER	EER	AHRI Capacity ²	AHRI Reference Numbers	HSPF	47°	17°
							Btuh	Btuh
HRG1418S1P	HCG24V1P	15.5	12.5	18,000	203216796	8.5	17,300	10,600
	HMG24F1P	14.25	12.2	18,000	203216838	8.2	17,600	11,000
	HMG24X1P	16	13	18,000	203216844	8.5	17,200	10,600
HRG1424S1P	HCG24V1P	15.1	12.5	24,000	203216803	8.5	21,600	13,800
	HCG30V1P	16	13	24,000	203216808	9	19,200	13,500
	HMG24F1P	14	12	23,800	203216841	8.2	22,200	14,300
	HMG24X1P	15.5	12.5	24,000	203216848	8.5	21,600	13,600
	HMG30F1P	14.5	12.5	23,800	203216851	8.5	19,600	13,900
HRG1430S1P	HCG30V1P	15.1	12.5	30,000	203216811	8.5	26,400	16,900
	HCG36V1P	15.5	12.5	30,000	203216816	9	27,000	17,400
	HMG30F1P	14	11.5	29,600	203216855	8.5	27,000	17,500
	HMG30X1P	15.5	12.5	30,000	203216862	8.5	26,200	16,800
	HMG36F1P	14.5	12.2	30,000	203216865	8.5	27,400	17,800
	HMG36X1P	16	13	30,000	203216873	9	26,800	17,100
36	HMG36F1P	14	12	33,400	203216869	8.2	31,200	20,000
	HMG36X1P	15	12.5	33,800	203216877	8.2	30,800	19,500
HRG1442S1P	HCG42V1P	15	12.5	41,500	203216819	8.5	39,000	25,800
	HCG48V1P	15.5	12.5	42,000	203216824	8.5	39,000	25,600
	HMG42F1P	14	12	40,500	203216880	8.2	39,500	26,200
	HMG42X1P	15	12.5	41,000	203216884	8.2	39,000	25,600
	HMG48F1P	15.1	12.5	42,000	203216887	8.5	39,000	25,800
	HMG48X1P	15.5	12.5	42,000	203216894	8.2	39,000	25,600
HRG1448S1P	HCG48V1P	14.5	12.2	48,000	203216827	8.2	46,000	28,600
	HCG60V1P	15.1	12.5	48,000	203216830	8.5	42,000	27,800
	HMG48F1P	14	11.5	47,500	203216891	8.2	46,000	29,000
	HMG48X1P	14	11.5	47,500	203216898	8.2	46,000	28,800
	HMG60F1P	15.1	12.5	48,000	203216901	8.5	42,000	27,600
	HMG60X1P	15.5	12.5	48,000	203216909	8.5	42,000	27,600
HRG1460S1P	HCG60V1P	14	12	56,500	203216834	8.2	55,000	35,800
	HMG60F1P	14.25	12	56,500	203216905	8.5	54,500	35,400
	HMG60X1P	14.25	12.2	56,500	203216912	8.2	54,500	35,400

Note: ¹ A blower time delay relay is required to achieve AHRI rating. This feature is standard on all furnaces and AH products

² Certified in accordance with Unitary Air Conditioner Certification Program, which is based on AHRI Standard 210/240

ACCESSORIES

Description	Where Used	Kit Number
TXV Kit	18, 24, 30	H4TXV01
	36, 42, 48	H4TXV02
	60	H4TXV03
Crankcase Heater	18, 24, 30, 36	93M04
	42, 48, 60	93M05 (Factory Installed)
Sound Blanket	12, 24, 30, 36	14W00 (Factory Installed)
	42, 48, 60	14W01 (Factory Installed)
Short Cycle Protector	All models	Control Board Feature
Freezestat	3/8 tubing	93G35
Electric Heat Outdoor Thermostat & Mounting Box	All models	1.841188
Fossil Fuel Kit	All models	1.841189
Liquid Line Solenoid	All models	60M5201
Single Power Point Supply	All models	21H39
Low Ambient (Cooling Operation)	All models	68M04
Mild Ambient (Cooling Operation)	All models	33M07
Cold Weather	All models	1.921145

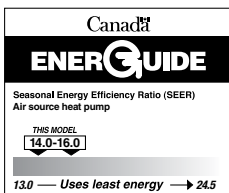

"This product complies with all California product labeling laws including, but not limited to, the Safe Drinking Water and Toxic Enforcement Act of 1986, more commonly known as Proposition 65."

Due to ongoing product improvements, specifications and dimensions are subject to change and correction without notice or incurring obligations. Determining the application and suitability for use of any product is the responsibility of the installer. Additionally, the installer is responsible for verifying dimensional data on the actual product prior to beginning any installation preparations.

Third party incentive and rebate programs have precise requirements as to product performance and certification. All products meet applicable regulations in effect on date of manufacture; however, certifications are not necessarily granted for the life of a product. Therefore, it is the responsibility of the applicant to determine whether a specific model qualifies for these incentive/rebate programs.